

GN 5345.4

Stainless Steel-Three-lobe knobs

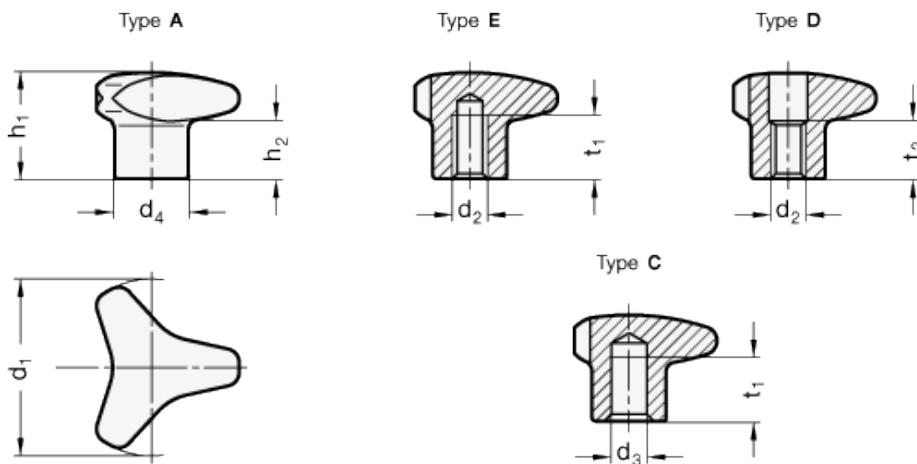

INOX
Stainless Steel



technical informations

Material

AISI 316L (A4) Stainless Steel, matt-blasted.

Standard versions available

- Type A: casting only.
- Type E: with threaded blind bore.
- Type D: with threaded through bore.
- Type C: with plain blind bore H7.

Special execution on request

highly polished (PL).

Features and applications

Stainless Steel-Three-lobe knobs GN 5345.4 have a smooth and sealed surface. They are particularly suitable for use where

hygiene requirements are high. Their shape allows relatively high torques to be applied.

Standard Elements	Main dimensions				Mounting holes				Weight
Description	d ₁	d ₄	h ₁	h ₂	d ₂	d ₃ H7	t ₁ min.	t ₂	g
GN 5345.4-40-A	40	18	26	15	-	-	-	-	90
GN 5345.4-50-A	50	21	30	17	-	-	-	-	127
GN 5345.4-60-A	60	25	35	18	-	-	-	-	216
GN 5345.4-40-M6-E	40	-	26	15	M6	-	12	-	65
GN 5345.4-40-M8-E	40	-	26	15	M8	-	15	-	70
GN 5345.4-50-M8-E	50	-	30	17	M8	-	15	-	109
GN 5345.4-50-M10-E	50	-	30	17	M10	-	18	-	138
GN 5345.4-60-M10-E	60	-	35	18	M10	-	18	-	190
GN 5345.4-60-M12-E	60	-	35	18	M12	-	22	-	232
GN 5345.4-40-M6-D	40	-	26	15	M6	-	-	13	67
GN 5345.4-40-M8-D	40	-	26	15	M8	-	-	13	70
GN 5345.4-50-M8-D	40	-	30	17	M8	-	-	16	109
GN 5345.4-50-M10-D	50	-	30	17	M10	-	-	16	140
GN 5345.4-60-M10-D	60	-	35	18	M10	-	-	20	193
GN 5345.4-60-M12-D	60	-	35	18	M12	-	-	20	230
GN 5345-40-B8-C	40	-	26	15	-	B8	15	-	70
GN 5345.4-50-B10-C	50	-	30	17	-	B10	18	-	114
GN 5345.4-60-B12-C	60	-	35	18	-	B12	22	-	195



STANDARD MACHINE ELEMENTS WORLDWIDE